

TOP VIEW

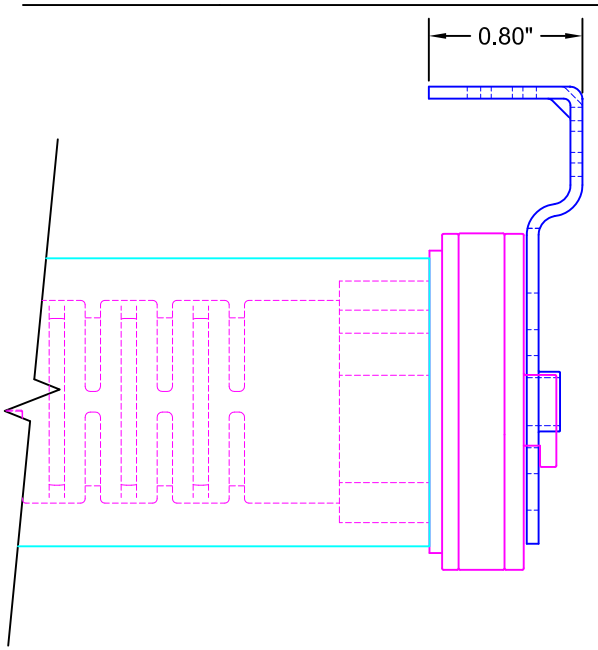

FRONT VIEW

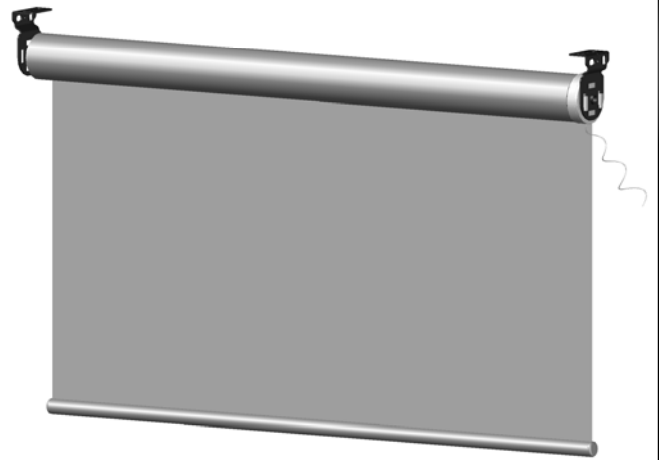
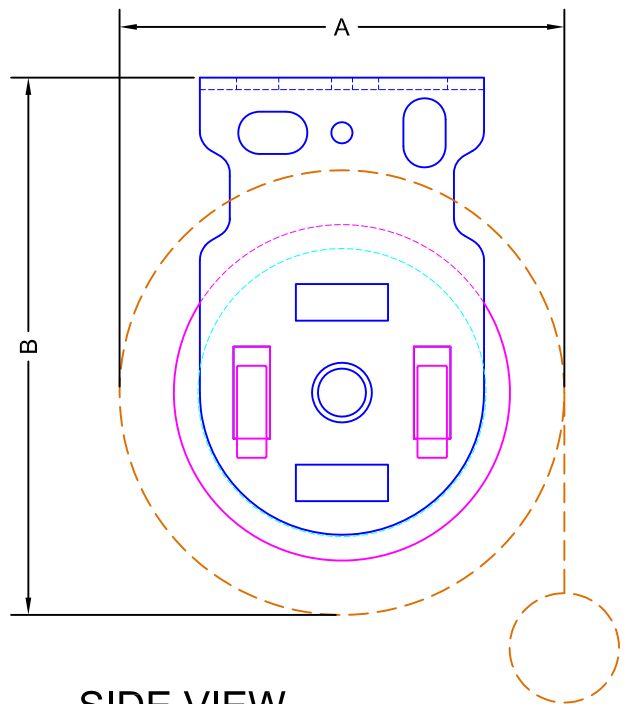

SIDE VIEW

SHADE HEIGHT	A	B
36"	± 1.97"	± 2.62"
48"	± 2.11"	± 2.70"
60"	± 2.24"	± 2.76"
72"	± 2.36"	± 2.82"
84"	± 2.47"	± 2.88"
96"	± 2.58"	± 2.93"

NOTE: DIMENSIONS BASED ON PHIFER SHEARWEAVE 4000 FABRIC

LEGEND

- 1.5" LEGACY BRACKET
- SONSESSE 30 MOTOR
- 1.5" ALUMINUM TUBE
- FABRIC W/ BOTTOM RAIL



3117 NW 25th Ave, Phone: 954.974.0525
 Pompano Beach, FL 33069 Fax: 954.974.0529

DESCRIPTION:

**SONESSE 30
 MOTORIZED SHADE**

*SHOWN ON 1.5" LEGACY SYSTEM

SCALE: 1" = 1"

DATE: 7/10/2012

SHEET NO:

R-9.1